

BETH

FUSES (ZE-700)

ZE-700S-MP

ZE-700S-MH

ZE-700S-MR

ZE-700S-MS

ZE-700S-A

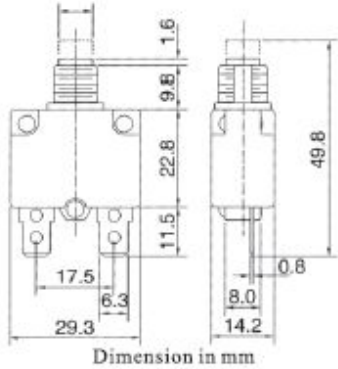

Parts

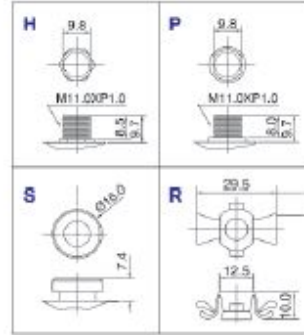

Parts



Terminal

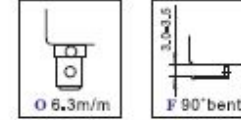

Approvals

* Approval: 3-15A 125/250VAC

Specifications

- *Standard Rating: 3-20 AMPER.
- *Input Power: 125 VAC/250 VAC.
- *Dielectric Strength: 1500 VAC/1 Minute.
- *Interrupt Capacity: 125 VAC×1000 A, 250 VAC×1000 A.
- *Insulation Resistance: >100 MΩ
- *Calibration: 25°C-105°C of Rated Current-Continuously Carried
25°C-Between 101% to 145%-May Trip or Not.
25°C-150% of Rated Current-Trip Within 1 Hour.
25°C-200% of Rated Current-Trip Within 1 Minute.
- *Contact Endurance:
125 VAC×150% of Rated Current-500 Cycles.
- *Reset: Manual Push Reset/Auto Reset.

MAX Internal Resistance	
3A-4A	0.120 Ω
4A-5A	0.120 Ω
5A-6A	0.100 Ω
6A-7A	0.075 Ω
7A-8A	0.035 Ω
8A-9A	0.020 Ω
10A-11A	0.015 Ω
12A-13A	0.010 Ω
13A-14A	0.010 Ω
15A-16A	0.008 Ω
18A-20A	0.007 Ω

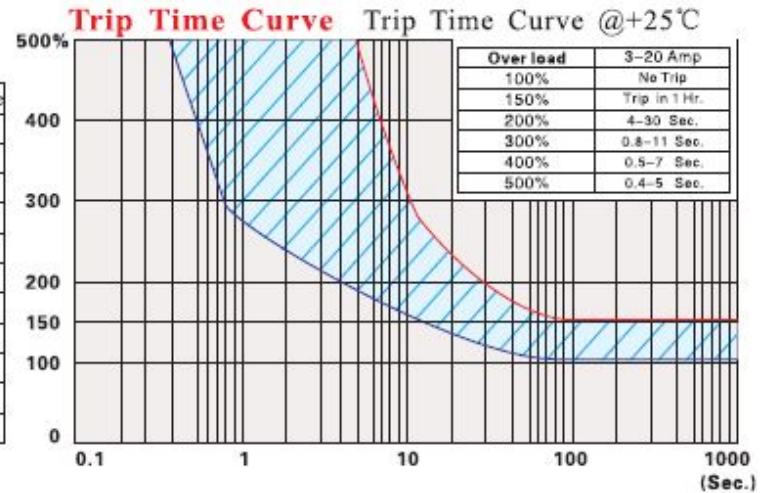

BETH

FUSES (ZE-700)

ZE-700-MH



ZE-700-MI



ZE-700-MR



ZE-700-A

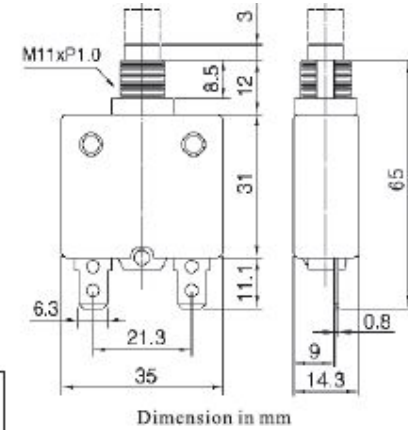

Bushing

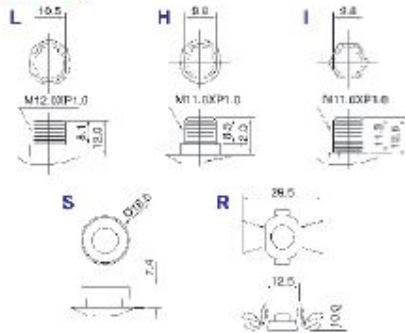

Parts



Terminal

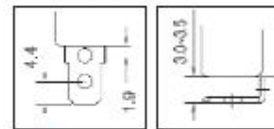

Nut



Approvals

- * Approval: 3-30A 125/250VAC
- * Approval: 5A, 10A, 15A, 20A, 125VAC

Specifications

- *Standard Rating: 3-50 AMPER.
- *Input Power: 125 VAC/250 VAC/50 VDC.
- *Dielectric Strength: 1500 VAC/1 Minute.
- *Interrupt Capacity: 125 VAC×1000 A, 250 VAC× 2000A.
- *Insulation Resistance: > 100 MΩ
- *Calibration: 25°C- 100% of Rated Current-Continuously Carried.
25°C-Between 101% to 145%-May Trip or Not.
25°C-150% of Rated Current-Trip Within 1 Hour.
25°C-200% of Rated Current-Trip Within 1 Minute.
- *Contact Endurance:
125 VAC×150% of Rated Current-500 Cycles.
- *Reset: Manual Push Reset/Auto Reset.

MAX.Internal Resistance	
3A-4A	0.100 Ω
5A-6A	0.035 Ω
7A-9A	0.020 Ω
10A-12A	0.015 Ω
13A-16A	0.010 Ω
17A-22A	0.006 Ω
23A-28A	0.005 Ω
29A-35A	0.004 Ω
36A-40A	0.003 Ω
41A-50A	0.002 Ω

Trip Time Curve

